

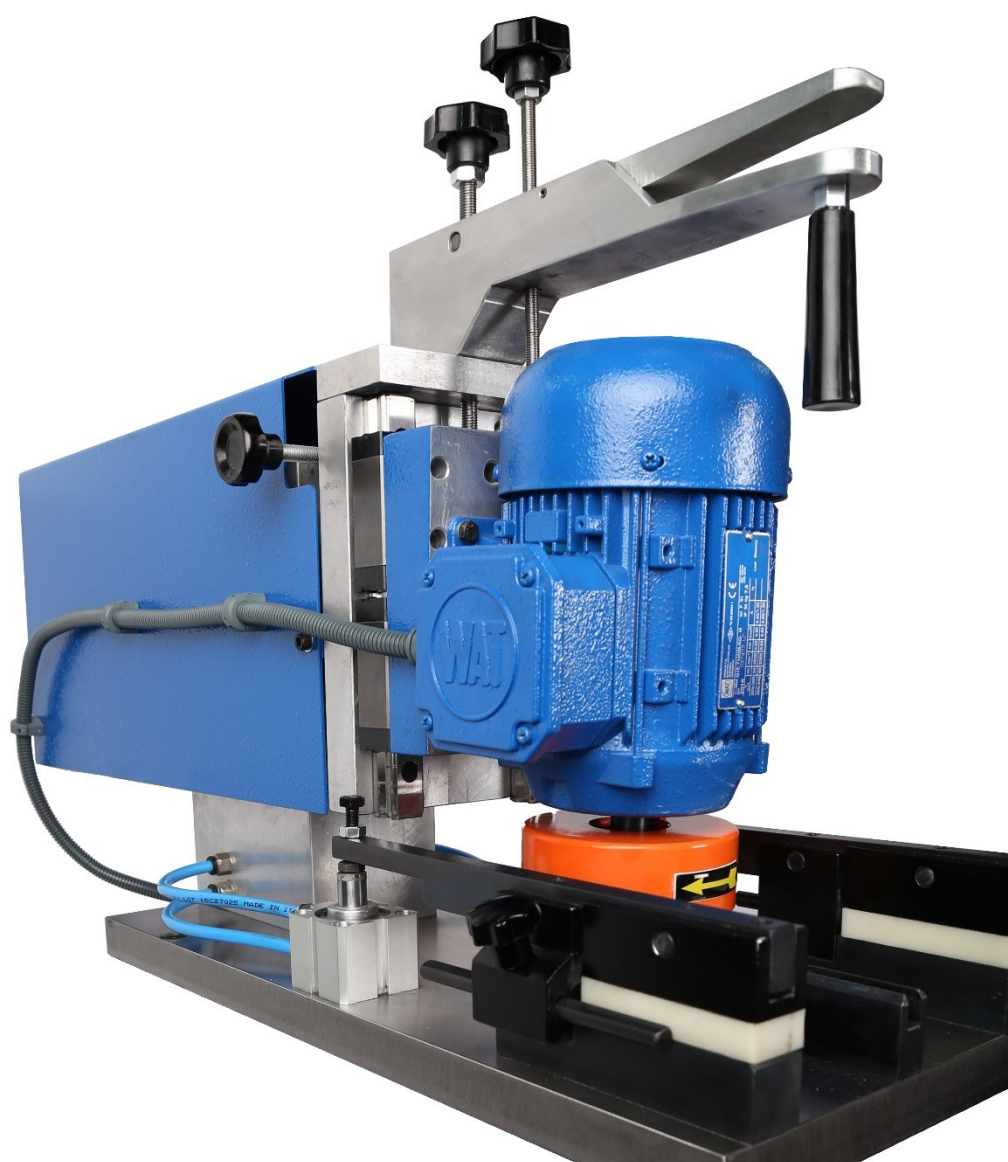

Temelsan®

TAS1001 SL HP ONLY SURFACE GRINDING MACHINE USER MANUAL



Congratulation to your new TEMELSAN Griding Machine TAS1001 SL HP

INDEX

BASIC INFORMATIONS	2
APPROPRIATE USE	2
WARRANTY AND LIABILITY	3
SAFETY	3
QUALIFIED PERSONNEL	3
PLANNING AND SET-UP	3
OPERATIONS	3
SAFETY DEVICES	3
AREAS OF USAGE	4
MAINTENANCE	4
ISSUES4	
SAFETY MEASURES RELATED WITH THE MACHINE	5
REQUIREMENTS OF WORKING PLACE	6
FIRST CONNECTIONS.....	6
POWER SUPPLY (WIRING DRAW SEE AT FOLLOWING PAGE)	6
PRESS-AIR REQUIREMENTS	8
FIRST INSTALLATION AND ADJUSTMENTS.....	8
START-UP THE MACHINE	8
OPERATION STEPS	8
EQUIPMENTS.....	9
SERVICE THE GRINDER.....	10
1- CHANGING THE WELDING LINE GRINDER	10

BASIC INFORMATIONS

This manual user guide is prepared to be useful in order to get familiar with the machine and the functions of the machine. By the help of this manual guide, the operator becomes a capable to use the machine in an optimal way in order to operationalize safely, ergonomically and properly.

This manual user guide allows the operators not to take risk, minimize the idle and repair time. It also helps to increase lifetime of the machine.

This manual user guide should be kept in a proper place and be accessible easily when needed. The local regulations included safety and environmental requirements must be followed in addition to the statements based on this manual user guide.

In case of an issue, complaint, request, demand on spare parts etc. please note the following information along with the below message

Concerning following Object:

Machine Model: TAS 1001 SL HP

Mfg. year: 2020

Serial Number: _____

APPROPRIATE USE

The machine is designed to grind the all dimensions of steel and band saw blades.

In the event of using the machine rather than described in which case the machine would be out of warranty situation of Temelsan.

Welding Line Grinding/ the machine is designed to make grinding on welding surfaces of steel and band saw blades. You have to select your grinding disk and replace on welding line grinder area.

WARRANTY AND LIABILITY

In the event of involving a personal injury or physical damages are not covered by the warranty if the following events occur as below.

- Using the machine for a purpose rather than intended
- Technically, improper installation, start-up operation or maintenance of the machine
- In the act of using the machine while any of safety equipment is a broken or protective device inappropriately running.
- Making constructional changes on running parameters.
- Insufficient control of abrasion parts
- Inappropriate repairs
- The catastrophic failures due to the action of foreign objects / Bodies and excessive force applied

SAFETY

Below safety requirements must be applied without skipping anything and priority case to carry out.

QUALIFIED PERSONNEL

Certain tasks must be carried out on the machine by a professional qualified personnel. Not third parties neither the children should be near the machine working area.

PLANNING AND SET-UP

Planning, transportation, installation, programming, start-up, maintenance, repairs and other works must be done by qualified personnel. Authorized technician must check it also.

The following matters must be noted:

- Technical data and details concerning the permissible use of the machine and its accessories.
- General and specific local preparation and safety measures.
- Personal usage and the use of general safety equipment must be related the norms.
- Especially listed on this manual guide but specifically not listed in the operating instructions that has been explicitly forbidden. Such as a handicapped to use the machine is such cases it is necessary to contact the manufacturing company.

OPERATIONS

Dangers hidden in disregards of safety regulations.

SAFETY DEVICES

The machine is equipped with the safety devices corresponding to current state of the art. In the matter of safety equipment, the machine may not be disabled, removed, dismantled, damaged. It applies in particular to:

- Covers (Welding Line Grinder protection, Back Edge Grinder protection)
- Safety switches (Emergency Stop Button)
- Electrical and electronic fuses

AREAS OF USAGE

The Grinding machine Temelsan TAS1001 SL HP is used for any kind of steel bands and band saw blades or bi-metal or carbide tipped band saw blades.

The grinding capacity for Band Saw Blades is from minimum 20x0.65mm up to a maximum 100 x1.60mm. The machine is capable to grind all kinds of band saw blades which are called carbon, wood, bi-metal, CT Work on the electrical power supply is only to be done by professional electrician.

The machine need to be assembled on work desk.

The machine can be set-up by the customer's own staff if officially approved by Temelsan.

Please read the following sections thoroughly and carefully before the initial start-up and ensure that you clearly understand it.

MAINTENANCE

In order to insure a safe operation on the machine and prevent accidents, the job listed in the section "Servicing" must be carried out regularly. If the owner of machine is not in a position to do that also must be arranged by an authorized service agent.

ISSUES

The machine must be switched off at once in case of any problem occurs during the operation and then locked for not being restarted accidentally by an unauthorized person.

The machine must be switched off in this case.

- Unusual sounds, vibrations, smells
- Increased temperatures or power consumption



WARNING!

Only suitably qualified personnel must service the machine!



EMERGENCY

ATTENTION!

Note the following at emergent cases (fire, explosions, breakage):

- Cut the machine off from the mains power supply at an external main switch or external fuses
- Switch off the compressed air supply
- Use the fire extinguishers of a suitable type to deal with the fire

SAFETY MEASURED RELATED WITH THE MACHINE**WEAR PROTECTIVE GLASSES!**

Grinding beads produced during grinding work could damage your eyes.

**WEAR GLOVES!**

The sharp edges of the blades can cause hand injuries.

**DANGER OF FIRE!**

Easily inflammable materials could be set alight if they come in to contact with welding sparks

**SWITCH OFF THE MACHINE!**

Cut off machine from the main supply before carrying out setting-up maintenance and servicing work on the machine.

**ATTENTION!**

It's dangerous when contacting parts of the power supply, control and transformer.

**IN CASE OF EMERGENCY;**

Push the emergency stop button.

The emergency stop button is to use by emergency issues only!

REQUIREMENTS OF WORKING PLACE

- Flat and smooth ground
- Required big enough area around the machine
- Environmental conditions
- The client is obliged to local electrical distributor notified technical requirements

FIRST CONNECTIONS

POWER SUPPLY (Wiring draw see at following page)



Make sure that the main switch of the machine is on OFF position and prevent to be turned on by an accident.

A qualified electrician must do the connection.

The input voltage (standard norm) is 380V AC (3 Phase + Neutral + Ground) 50Hz.

The recommended power supply cable is 4x2,5mm

RST marks for phase connections, N mark is Notr Connection and Yellow Green cable is for World connection.

The Diameter of each wire for power supply it's very important, please use the chart by selecting the Machine Type

Do not switch ON the machine before the all setup instruction is read and work performed



ATTENTION!

Pay special attention to protect yourself from the energized cables moreover the control panel while operating the machine. Keep closed the cover of electrical control panel and do not forget to take out all the foreign objects in the cabinet which might cause short circuit.



WARNING!

- Working on the electrical power supply has to be only done by professional electrician.
- The electrical equipment of the machine must be checked regularly
- Always keep the switching cabinet locked. Access is only permitted to authorized personnel with the key or special tool.

- Remove at once any loose or worn cables
- If it is essential to work on parts carrying a current there must be a second person present to turn off the main switch in case of an emergency
- The customer is required to comply with the technical conditions and requirements of the relevant electrical power supply company

		KABLO / CABLE							
MAKİNE MODELİ MACHINE TYPE	TRAFO KVA	ŞEBEKE GERİLİMİ LINE VOLTAGE	SİGORTA GEÇİKMELİ FUSE SLUGGISH TYPE	KABLO MODELİ CABLE TYPE	KABLO UZUNLUK CABLE LENGTH	NOMİNAL KESİT NOMİNAL CROSS SECTION	DIŞ ÇAP OVERALL DIAMETER	İLETKEN TEL SAYISI VE ÇAP NUMBER OF CONDUCTING WIRE	
		VOLT AC	AMPER		METER	mm ²	mm	mm	
KN41 HBS	4.5 KVA	400 VAC	50	TTR	< 5	5x10	21	6	
KN67 HBS	12 KVA	400 VAC	63	NY	< 5	3x16 + 10 +10	23	7x1,7	
KN67 HBA	40 KVA	400 VAC	63	NY	< 20	3x25 + 16 +16	25	7x2	
KN100 HBA	63 KVA	400 VAC	63	NY	< 50	3x35 + 16 +16	32	7x2,4	

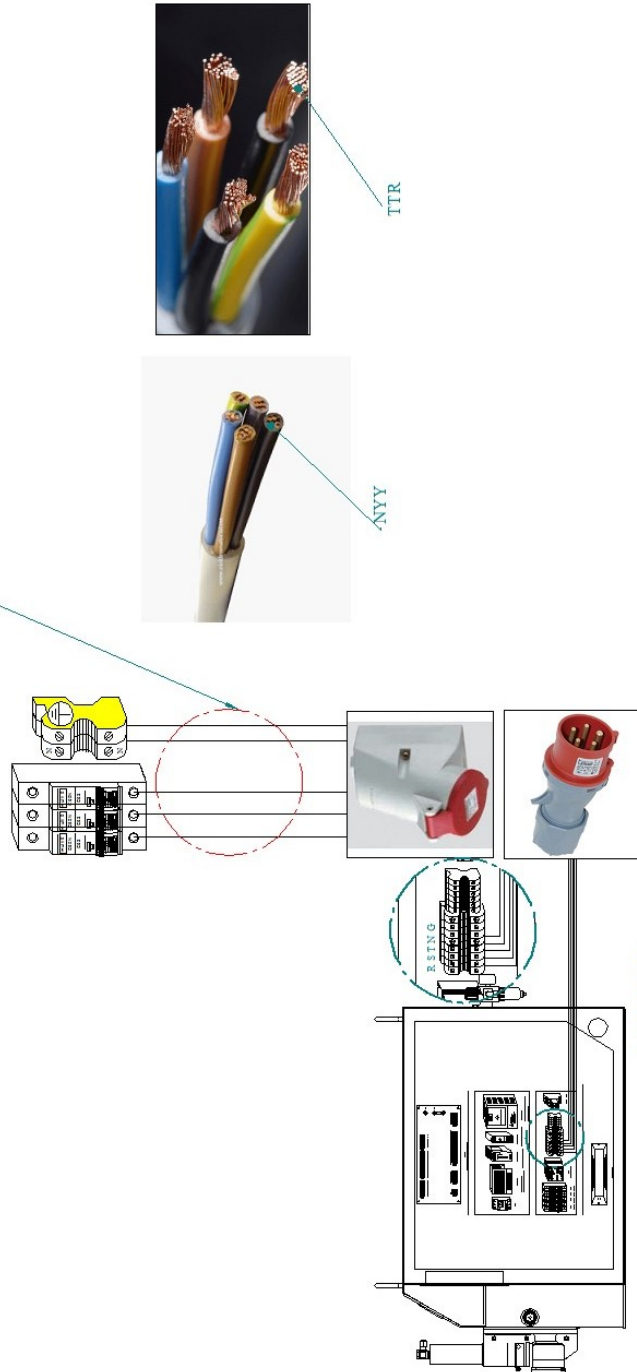

MAX 5 METER
NY 3X16+10+10
(KN41 HBS TTR 5X10)

PRESS-AIR REQUIREMENTS

The machine needs dry and clean air pressure, which needs 6-8 bars. The reservoir capacity of the air compressor should be at least 150 liters.

Air Supply Check

Main Air Supply minimum 6 maximum 8 Bar

The compressor should be adjusted as starting to fill the air by 6 Bar and stop to fill by 8 Bar if Clamping Pressure does not reach the enough capacity, the main air pressure is too low never adjust the main Air pressure over 8 Bar. Factory adjustment is 9,5 Bar The Tube size for Air Pressure supply is minimum 12x10 mm.

FIRST INSTALLATION AND ADJUSTMENTS

Authorized professionals, who must read this user guide, must do first installation and adjustments. In case of questions, is an immediately contact with manufacturer/supplier required.

START-UP THE MACHINE

1. Turn the main power switch to ON
2. Check and unlock the Emergency Stop Button (to unlock turn on Button to left side)
3. Pull the head from PULL HANDLE for Ready to Use

OPERATION STEPS

- 1- Open the clamping jaws by pushing the **“CLAMPING JAWS OPEN-CLOSE PEDAL”**
- 2- Replace your Band Saw between the Jaws
- 3- Close the clamping jaws by pushing the **“CLAMPING JAWS OPEN-CLOSE PEDAL”**
- 4- Set the distance of Grinding Disk from saw surface by using the **“UPPER-LOWER DISTANCE ADJUSTMENT HANDLE”**
- 5- Pull the **“PULL HANDLE”**
- 6- Slide the **“WELDING LINE GRINDER”** on band saw surface, while sliding the grinder use the **“GRINDING DISTANCE HANDLE”**
- 7- Repeat the steps 2,3,4,5 AND 6 to another side of band saw

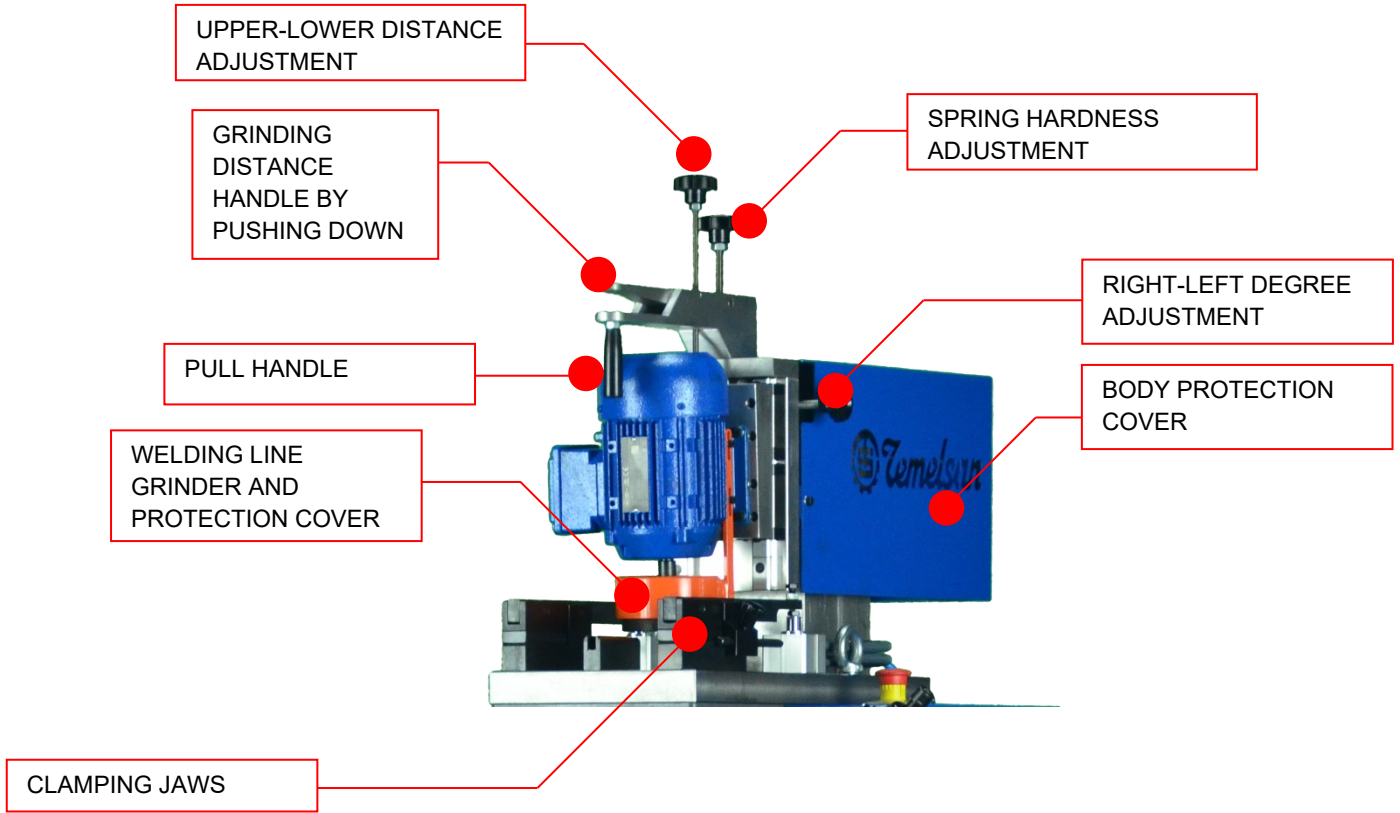
EQUIPMENTS

SERVICE THE GRINDER

1- CHANGING THE WELDING LINE GRINDER

While using the machine grinder will be smaller and its

- First will need to move protection cover of Welding Line Grinder.
- You can adjust Protection Cover by the size of Grinding Disk to unscrew those two screws.
- Push the Grinder on front and screw the Handle from back side on Clockwise (right side picture)
- Change the Grinding Disk
- Unscrew Handle on Counterclockwise

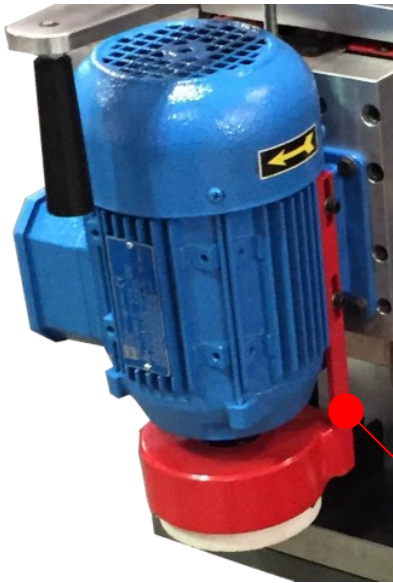

HANDLE ON BACK
SIDE OF MACHINE

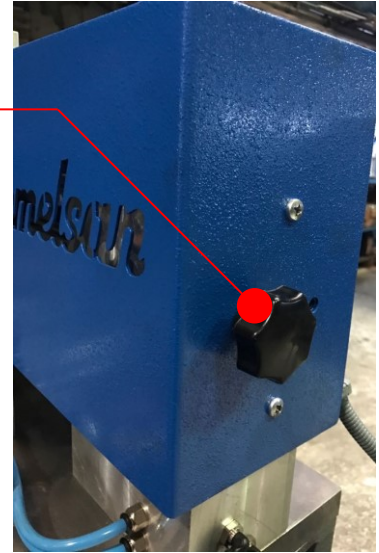

PROTECTION COVER
LEVEL ADJUSTMENT
SCREWS

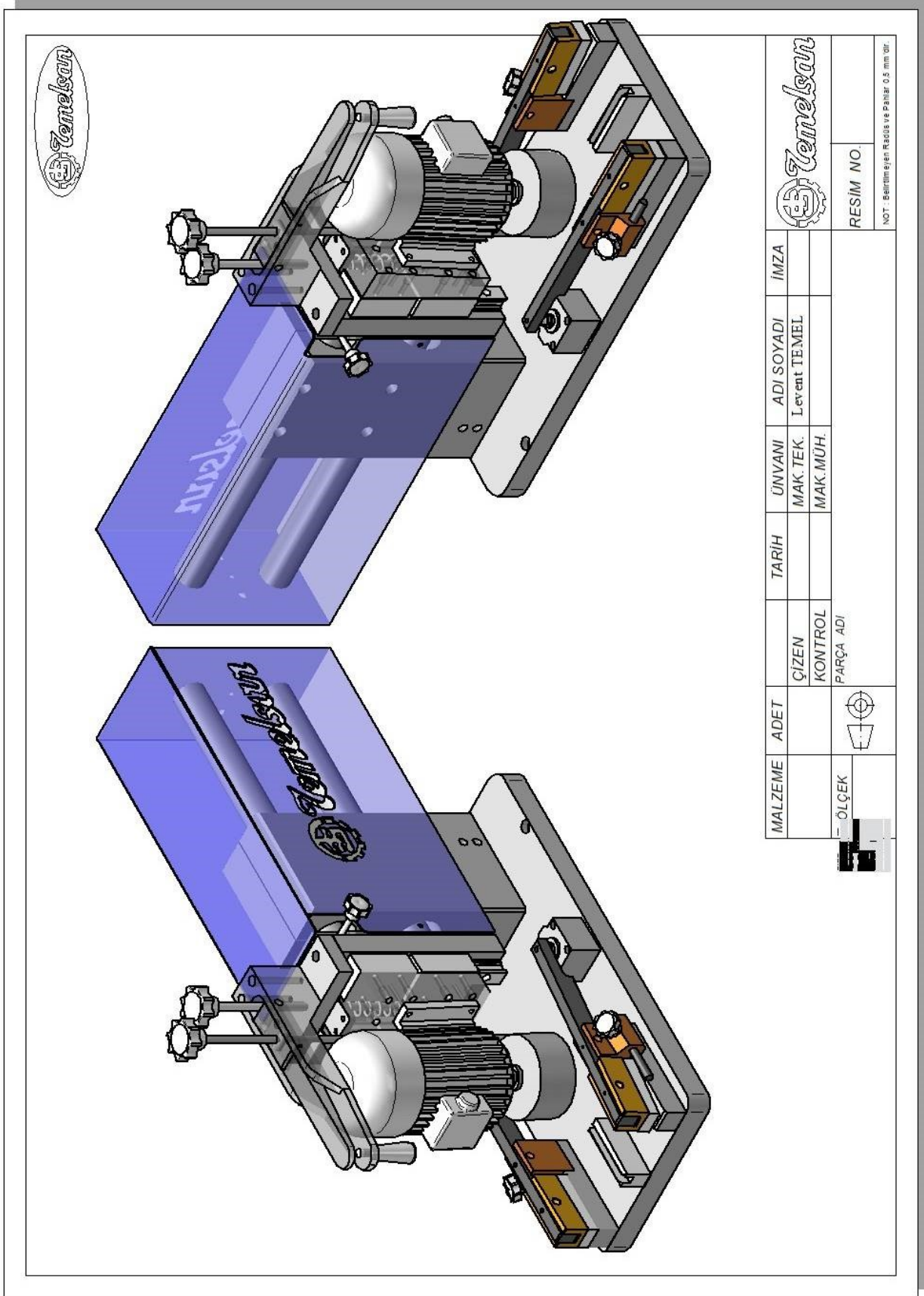

MALZEME	ADET	ÇİZEN	TARİH	ÜNVANI	ADI SOYADI	İMZA
		KONTROL		MAK.TEK.	Levent TEMEL	
		PARÇA ADI		MAK.MÜH.		
ÖLÇEK						RESİM NO.

NOT: Belirtilmeyen Raporis ve Parolar 0.5 mm dir.



MALZEME	ADET	ÇİZEN	KONTROL	TARİH	ÜNİVANİ MAK. TEK.	ADI SOYADI L. ev'ant TEMEL	İMZA
ÖLÇEK							

TAŞ DENE MONTAJ. asm

RESİM NO

NOT: Belirtilmeyen Rastus ve Pahalı 0.5 mm dir.

İtem Number	Quantity	File Name
1	1	ALT TABAN 01.par
2	1	RULMAN YATAK 01.par
3	2	İNDİKSİYONLU MIL 4.0.par
4	1	TAŞ DENE.asm
5	1	TESTERE ORTAŞI.par
6	1	KAPAK 1.psm
7	1	KAPAK2.psm
8	2	HAVA PİSTON 4.0 LİK.par
9	1	TES SIKMA MONTAJ.asm
10	1	TES SIKMA MONTAJ SOL.asm
11	2	BK50x10.par
12*	2	BK32x40xM8.par